



Building over Sewers Policy

For more information contact
Shoalhaven Water

City Administration Centre

Bridge Road (PO Box 42)
Nowra NSW Australia 2541
P: (02) 4429 3214
F: (02) 4429 3170
water@shoalhaven.nsw.gov.au
www.shoalwater.nsw.gov.au

Policy Number: POL16/81

Adopted: 18/02/1997

Amended: 20/05/2008, 25/11/2008

Reaffirmed: 3/09/2013

Minute Number: MIN97.26, MIN06.1434, MIN08.1534, MIN13.858

File: 33249E

Review Date: Thursday, 1 December 2016

For more information contact Shoalhaven Water

City Administrative Centre

Bridge Road (PO Box 42), Nowra NSW Australia 2541

P: (02)4429 3214 F: (02) 4429 3170

water@shoalhaven.nsw.gov.au www.shoalwater.nsw.gov.au

Disclaimer

Every effort has been made to provide accurate and complete information. However, Shoalhaven City Council assumes no responsibility for any direct, indirect, incidental or consequential damages arising the use of information in this document.

Copyright Notice

No part of this publication may be reproduced in any form or stored in a database or retrieval system, or transmitted or distributed in any form by any means, electronic, mechanical photocopying, recording, or otherwise without written permission from Shoalhaven City Council. All rights reserved. Copyright © 2013, Shoalhaven City Council.

Contents

| | | |
|-----|-------------------------------------|----|
| 1 | PURPOSE | 3 |
| 2 | STATEMENT | 3 |
| 2.1 | Glossary | 3 |
| 2.2 | Abbreviations | 4 |
| 3 | PROVISIONS | 4 |
| 3.1 | Restrictions/Exemptions | 4 |
| 3.2 | Submission Requirements | 5 |
| 3.3 | Supervisions/Inspection | 6 |
| 3.4 | Works as Executed Plans | 6 |
| 3.5 | Principles Adopted | 7 |
| 4 | IMPLEMENTATION | 11 |
| 5 | REVIEW | 11 |
| 6 | APPLICATION OF ESD PRINCIPLES | 11 |
| 7 | MINOR AMENDMENTS | 11 |
| | Appendix A | 12 |
| | Appendix B | 13 |
| | Appendix C | 14 |
| | Appendix D | 15 |

1 PURPOSE

This policy document has been prepared as a guideline for proposed development/s where approval is required from Shoalhaven Water for building over or adjacent to Council's gravity sewer mains. The implementation of this policy will ensure that Council's sewer assets are protected.

2 STATEMENT

Shoalhaven Water's (SW) first position is that structures not be constructed over or close to sewers.

Applications for construction adjacent to and over SW's assets will only be entertained if it can be clearly demonstrated that the applicant has investigated all other options for development.

SW will treat each application on its merits but it should not be assumed that consent for construction over or near the sewer will be automatically granted.

2.1 Glossary

Sewer means an asset owned by Council used for the conveyancing of sewage, whether raw or treated. A sewer may be 'live' or disused.

Building over sewer means the erection of a structure over and within the zone of influence of the sewer.

Building adjacent to sewers means where a structure is proposed to be built in the zone of influence but not over the sewer. The structure is likely to impact on SW sewers and associated structures.

Zone of influence means the area associated with SW assets that, if built within or over, could cause undue loading on the asset. See appendix A for general calculations of zone of influence.

Lightweight/demountable structures means any approved structure (by Council's Development Services Group) that can at the owners risk and expense be easily and readily dismantled and removed at the request of Shoalhaven Water. Some examples may include domestic carports, some small tool or garden sheds.

Sewer survey / peg-out means the process where SW assets are located and correctly documented by a Registered Surveyor

Encasement means the protection of a sewer pipe by encasing all around with concrete to SW standards

Easement to drain sewage means a legal entitlement placed over a parcel of land for the purposes of the provision, operation and maintenance of sewer infrastructure.

Sewer line/main/pipe means an asset owned by Shoalhaven City Council, controlled and maintained by Shoalhaven Water Group, used for the conveying of sewage whether raw or treated. Note: A sewer may be in operation or disused.

Pressure sewer unit means a Council owned and maintained individual lot sewer pressure pump unit.

Sewer pressure main means the pipe running from the pressure sewer unit to the boundary kit.

Boundary kit means a Council installed valve box located on the sewer pressure main at the property boundary.

2.2 Abbreviations

| | |
|--------------|------------------------------------|
| AC: | Asbestos Cement |
| AHD: | Australian Height Datum |
| AS: | Australian Standard |
| CCTV: | Closed Circuit Television |
| 1H: | 1V - One Horizontal : One Vertical |
| mm: | millimetres |
| MPa: | Mega Pascal |
| SW: | Shoalhaven Water |
| uPVC or PVC: | Unplasticised polyvinyl chloride |
| VC: | Vitrified Clay |

3 PROVISIONS

3.1 Restrictions/Exemptions

3.1.1 Restrictions

Structures will not be permitted to be built over and/or in close proximity to the following:

- a) Sewer rising mains, surcharge mains and critical gravity mains (generally all sewer mains of greater diameter than 150mm mains and/or deemed to be excessively deep ie. greater than 3.0m), as determined by SW.
- b) Concrete pipes, asbestos cement pipes or vitreous clay pipes. However if local conditions permit, these pipes can be replaced with alternative pipes types, subject to approval by SW. In most circumstances SW will provide the replacement pipe.
- c) Any gravity sewer that, in the opinion of SW, is in a poor condition. Exposing of the sewer so that it may be inspected by the SW and, if necessary, repaired or replaced, may be a requirement. If replacement of the pipe is undertaken, in most circumstances SW will provide the replacement pipe.
- d) Any gravity sewer where sufficient clearances cannot be achieved (See section 3.5.2 for clearances).

- e) Sewer manholes, lampholes, maintenance points and junctions where sufficient clearances cannot be achieved. These structures enable ventilation of the sewer and provide access for maintenance and inspection. (See Section 3.5.2 for clearances)
- f) Sewers in water charged ground unless normal building over sewer precautions can be taken and approved by Shoalhaven Water.
- g) Where access to adjacent land is required to undertake the works and access to enter is NOT granted by the adjacent landowner.

3.1.2 Exemptions

Some lightweight structures (See Section 2.1) may be exempt from certain conditions set down in this policy, as noted below;

- a) If the proposed structure/s are approved by Council as readily demountable structures and can be easily dismantled by the owner at their own risk and expense, at any time, as requested by Shoalhaven Water. The applicant may need to provide information confirming the above.
- b) If the proposed structure/s do not place a superimposed load on the sewer main and do not prevent reasonable access to the sewer main either at the stage of construction or in the foreseeable future (owing to alteration of the structure).

In general, each case will be assessed on its merits after lodgement of a Development Application with consideration being given (but not limited to) the loads imposed on the sewer, accessibility to sewer mains, the criticality and type of sewer.

3.2 Submission Requirements

3.2.1 General

A written application including the following information is to be provided:-

- a) Two (2) copies of the approved Building plans.
- b) Two (2) copies of certified engineering plans, indicating protection requirements of the sewer infrastructure and proposed/existing structure(s). One copy will be retained by Shoalhaven Water,
- c) Site survey plan by Registered Surveyor accurately showing the location of the existing sewer (not a line between manhole lids) dimensioned both vertically and horizontally with respect to the lot boundaries and the proposed structure(s). Details to include offsets (square off the sewer main) and sewer chainages at those offsets, grade of the sewer main, AHD invert levels and surface levels at the affected footprint of the building. All dimensions indicated on the plan should be established by site survey and levels to AHD and not copied from Council's records.
- d) In certain circumstances SW will require a work method statement showing the sequence of construction and method of protecting the sewer.

3.2.2 Plan Requirements

The plans must clearly indicate:

- a) Engineering/building plans should set out the manner of construction, the type of material to be used and the precise location of the proposed and existing structure/s in relation to Council's sewers and other structures (offsets from sewer to structures/face of piers, to be provided), property boundaries and adjoining buildings (if deemed to affect the sewer), existing/finished surface levels at the building and over the sewer, and sewer invert levels. It is the applicant's responsibility to ensure accuracy of all information provided,
- b) Site soil classification as per AS 2870 (as amended) for the proposed development lot,
- c) Proposed or existing concrete encasement of the sewer main and compliance with protection, clearance and access requirements, plus any other conditions as indicated on the Development Application Notice,
- d) Details of the existing sewer pipe ie. location (offsets) of main and manholes/lampholes in relation to property boundaries and proposed structures and face of piers (as determined by Registered Surveyor), invert levels, grade of pipeline, material type (ie. uPVC, VC, AC etc.),
- e) Long sections showing cut / fill of site, invert levels of the sewer(s), floor levels, finished and /or natural surface levels and levels of underside of foundations with appropriate clearances. (See Appendix D),
- f) All levels shall be to AHD,
- g) All plans shall include detailed construction notes.

3.3 Supervisions/Inspection

- a) All works relating directly to the sewer infrastructure, as specified in the Development Application Notice and Building Over Sewer approval are to be carried out in the presence and to the satisfaction of SW's inspection officer. Inspection for any works should be arranged and confirmed at least 48 hours in advance. Applicants are to contact SW to determine the number of inspections and at what stage/s these are required prior to commencing any works.
- b) CCTV inspection of affected sewers may be required prior to issue of a Construction Certificate and/or at the completion of works.

3.4 Works as Executed Plans

At the completion of the approved works, if there has been engineering changes on site to the sewer, it is the Engineer/Surveyors responsibility to submit two (2) copies of Works as Executed plans supplied by a licensed surveyor prior to final approval.

3.5 Principles Adopted

3.5.1 Zone of Influence

The 'zone of influence' of a sewer is that area of soil/strata that is likely to be influenced by building loads. Factors that determine the 'zone of influence' include:

- Width of trench (Refer to Appendix A)
 - Depth of trench (Refer to Appendix A)
 - Soil classification by a qualified Structural Engineer as per AS 2870 (as amended)
 - Groundwater / level of the water table (Refer to Appendix A)
- a) The boundary of the 'zone of influence' coincides with the angle of repose of the strata encountered (including cut/fill). This boundary shall commence at the bottom corner of the trench nearest the proposed foundation. If the trench is partly in rock or shale the boundary shall commence at the top of the rock or shale strata. In heterogeneous soil the angle of repose may differ.
- b) The above criteria do not apply to water charged strata. Foundations in water charged ground are to be designed by a consulting engineer and approved by Shoalhaven Water.

3.5.2 Clearances

To ensure all sewer infrastructure is protected from damage and to enable maintenance, minimum clearances are required to be maintained from proposed structures.

3.5.2.1 Sewer mains/pipes

- a) Where a proposed building is permitted to be constructed over a sewer there shall be a minimum 250mm vertical clearance between underside of the foundations/beam and the top of the pipe concrete encasement. Where 250mm clearance cannot be achieved or in special circumstances alternative construction methods may be considered, upon application. Vertical clearances of less than 100mm will not be permitted.
- b) Where the zone of influence is 1H:1V and sewer trenches are less than 2.5m deep, the face of any foundations should be a minimum 1200mm clear of the centreline of small pipes (150mm or 225mm dia) or a minimum 1200mm clear of the outside face of larger sewers. In special circumstances these clearances may be reduced to 600mm but only if the trench depth is less than 1.5m and in rock or clay and the piers are constructed by open excavation. For deeper sewers ie. greater than 2.5m deep; the horizontal clearance shall be a minimum of 2.0m.
- c) Where the zone of influence is greater (flatter) than 1H:1V horizontal clearances from the face of piers to the centreline of sewer of less than 1200mm will not be permitted.
- d) Where the zone of influence is 1H:1V and for sewer depths of between 2.5m and 3.0m minimum clearance from the centre of the main for pipe sizes 150mm and 225mm or from the external face of pipe for larger sizes, shall vary on a pro-rata basis from 1200mm (2.5m deep) to 2000mm (3.0m deep).

- e) Where the zone of influence is other than 1H:1V, for sewers at depths greater than 2.5m the minimum clearance from the centre of the main for pipe sizes 150mm and 225mm or from the external face of pipe for larger sizes, shall be 2.0m.
- f) See below table for minimum cover over sewer pipes:

| Minimum Cover Requirements for Sewers | |
|--|----------------------------|
| Location of Pipe | Gravity Sewers – All Pipes |
| Areas not subject to vehicular loading | 450mm |
| Areas subject to vehicular loading: | |
| a) Not in roadway | 600mm |
| b) In sealed roadway | 750mm |
| c) In unsealed roadway | 750mm |

3.5.2.2 Manholes, Lampholes, Maintenance Shafts and Terminal Maintenance Shafts

Unrestricted access to all manholes, junctions, lampholes and/or maintenance shaft to be provided and maintained at all times. The following minimum clearances from these access points are required.

Note: Any arrangements involving access to a sewer through the floor of any building is NOT permitted.

- a) No building, wall or other improvement will be permitted within 1200mm horizontal radius from the centre of a manhole or maintenance shaft and within 750mm horizontal radius of a junction, lamphole or terminal maintenance shaft. It should be noted that these distances may be increased in certain circumstances.
- b) A minimum vertical clearance of 2400mm is to be maintained for all structures.
- c) Where a building is proposed to extend across the whole frontage of the building block, provision will be made to ensure that access for machinery to the manholes, lampholes, maintenance shafts and terminal maintenance shafts at the rear of the building is available at all times. Access from adjoining properties, unless they are public reserves, can only be relied on if an easement leads to the subject property to provide permanent access.

3.5.3 Foundation Requirements

- a) The foundations of any structure at and within 1200mm horizontal clearance from a sewer shall be founded minimum 150mm below the invert of that sewer or on sound rock. Concrete encasement of the sewer is required in accordance with section 3.5.4 below. Refer Appendices B and C.
- b) The foundations of any structure greater than 1200mm horizontal clearance and within the zone of influence of a sewer shall be founded minimum 150mm below the zone of influence relative to the trench. Refer Appendices B and C.
- c) The building and its foundations are to be designed in such a way that no building loads are transmitted to Council's sewer and where possible, the pipe can be repaired or replaced at any time without affecting the stability of the building.

- d) Displacement piles or shoring will not be permitted within 5 metres of a sewer.
- e) Screw piles will be permitted no closer than 2.0m to a sewer. Screw piles permitted to be located between 2.0m and 5.0m offset from the sewer are to be cored (min. $\frac{3}{4}$ dia of helix) to a level 300mm below the invert of the sewer.
- f) Certified Engineers design/construction details are required to show the design of footings, piers and beams with specified clearances, ground levels, together with soil classification.

3.5.4 Concrete Encasement

Concrete encasement of the sewer main is required for the protection of the affected pipe and any associated infrastructure due to the vertical loads imposed by the works and as a result of loss of access. Concrete encasement is also required where the cover of the strata over the pipes does not meet the minimum cover requirements. (See table, refer 3.5.2.1)

Concrete encasement is to comply with the following specification:

- a) Only rubber ring jointed vitrified clay and PVC pipes may be encased in concrete. Permission may also be given to replace other types of pipes with PVC pipes prior to encasement depending upon the location and criticality of the lines.
- b) In trenches of material other than rock, encasing is to extend 150mm under, on both sides and on top of the pipe barrel. The maximum width of the encasement is not to exceed 600mm. For trenches in rock, encasing is to extend 100mm under the pipe barrel, 150mm on top of the pipe barrel and for the full width of the excavated trench.
- c) Unless otherwise specified, all flexible pipe joints are to be maintained. The minimum length of the encasement will be the total length of the sewer that is affected plus a minimum of 1000mm on the each side plus any additional length to ensure encasement starts and finishes at a flexible joint. (Subject to soil conditions and depth of sewer this length may increase)
- d) If a manhole is less than 2 metres from the end of encasement, as required above, the encasement is to be extended up to the second flexible joint from that manhole.
- e) The applicant/developer will be required to locate the main, excavate the trench in accordance with Work Cover guidelines, identify the type of pipe to ensure encasement is possible, supply and construct any formwork required and supply and place the concrete (minimum 28 day strength of 20 MPa) in accordance with relevant standards. If the pipe has to be replaced in order to encase, the cost associated with these works are to be at the applicants' expense. Prior to any works commencing, SW Operations division need to be notified and allowed to inspect as required.
- f) If Asbestos pipes are to be replaced, removal and disposal of the pipes and any other AC material is to be undertaken in accordance with OH & S guidelines at the applicants' expense.
- g) Backfilling of the trench with suitable material as per specification must not commence until at least 48 hours after placing the concrete.

- h) Concrete encasement shall not be poured integral with any other foundation or structure.
- i) Sewer junctions that are permitted to be incorporated in proposed concrete encasement are to be upgraded to a rubber ring jointed junction in order to maintain flexibility at the junction branch.
- j) Where the encasing of sewers in adjoining properties is required, written approval from the adjoining owner to enter the property to carry out the works will be required prior to approval being granted for works to commence.

3.5.5 Rainwater Tanks

Rainwater tanks that are to be constructed on concrete slabs, frames or other permanent bases, will for the purposes of this policy, be classified as permanent load bearing structures and will be subject to the provisions of this policy in regard to access and load bearing upon Council's sewers.

Rainwater tanks of a size 10,000 litres or less, constructed from plastic or other flexible material and to be situated upon natural ground or a base of sand, roadbase or similar material, and where it can be demonstrated that the tank can be readily emptied and moved (without damage to the tank) will be classified as demountable structures and not be subject to the provisions of this policy.

3.5.6 General

- a) The placing of fill to excessive depths over sewers is not permitted (5000mm is a maximum depth for practical access to a sewer). Additional filling to increase the depth to greater than 2500mm above the sewer will require checking for loading on the sewer pipe.
- b) It is the applicants/developers responsibility to locate all services within the vicinity of any sewer infrastructure prior to excavation.
- c) Rebuilding of any premises is subject to the same conditions as would be imposed in respect of an entirely new building/structure or part thereof.
- d) Where satisfactory arrangements for building over a sewer cannot be provided, deviation of the sewer at the owner's expense where practicable, may be considered. Generally each case must be treated on its merits having regard to the type and importance of the sewer, the nature of the strata, feasibility of re-designing or relocating the existing sewer and/or the proposed building etc.
- e) Where excavation works for sewer encasement are likely to affect adjacent structures either on the subject property or on adjoining lands, underpinning or other approved methods of support of these structures will be required.
- f) Pressure sewer systems are to be treated in a similar fashion to normal gravity sewer in regard to building over sewer conditions. The zone of influence is to commence from a point 150mm below and 150mm horizontally away from the base of the pressure unit. No building, wall, foundations or other improvement will be permitted any closer horizontally than 1200mm to the unit. Foundations at 1200mm offset are to be founded a minimum 150mm below the base of the unit. A minimum vertical clearance over the unit of 2400mm is to be maintained. Access to

the unit for maintenance and repairs is to be maintained at all times. No structures are to be constructed over the sewer pressure mains running from the unit to the boundary kit. If required, and subject to application, relocation of the pressure main from the unit to the boundary kit may be approved.

4 IMPLEMENTATION

The Planning & Development Section of Shoalhaven Water has responsibility to implement this policy.

5 REVIEW

This policy will be reviewed within one year of the election of every new Council, or earlier should circumstances change to warrant a review.

6 APPLICATION OF ESD PRINCIPLES

None applicable.

7 MINOR AMENDMENTS

Minor amendments to this policy may be approved under delegated authority to the Director of Shoalhaven Water Group.

Appendix A

BUILDING OVER COUNCIL'S SEWER

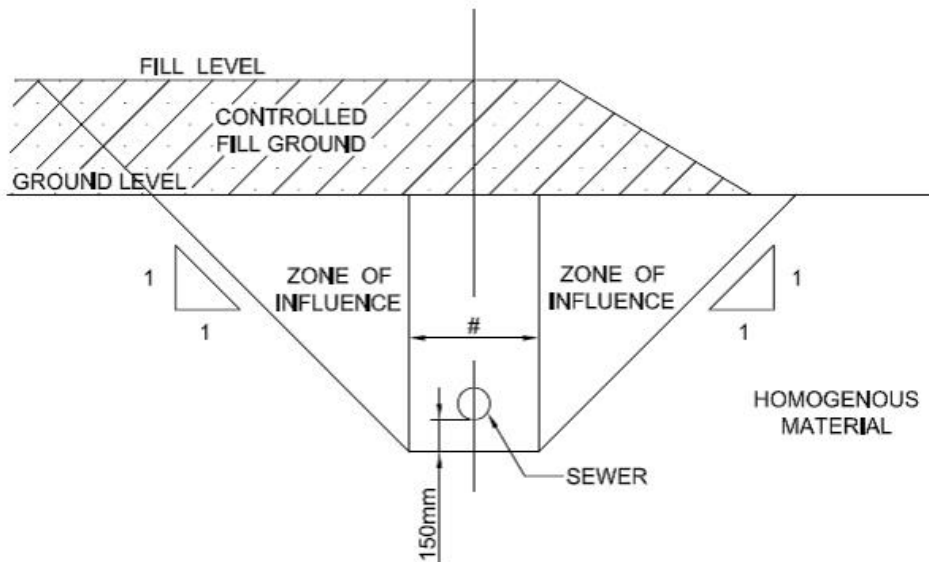

DIAGRAM 1 - ZONE OF INFLUENCE - CLAY, COMPACTED SOIL, ETC.

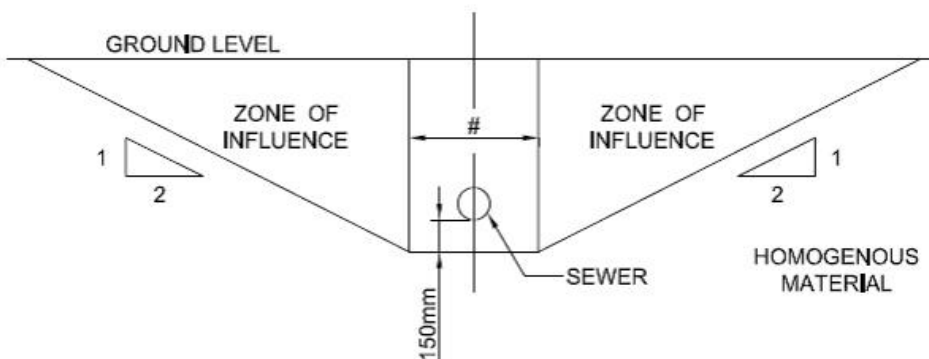

DIAGRAM 2 - ZONE OF INFLUENCE - SAND, FILLED GROUND, LOAM, ETC.

NOTE: IN WATER CHARGED GROUND, THE ZONE OF INFLUENCE MAY EXTEND FURTHER FROM THE SEWER.

(A) 600 mm - TYPICAL FOR PIPES UP TO 300 mm DIAMETER NOT REQUIRING TRENCH SUPPORT.

(B) 900 mm - FOR PIPES GREATER THAN 1.5m DEEP AND/OR WHERE TRENCH SUPPORT MAY BE REQUIRED.

Appendix B

BUILDING OVER COUNCIL'S SEWER
TYPICAL DETAILS FOR 150Ø & 225Ø UPVC AND VC PIPES

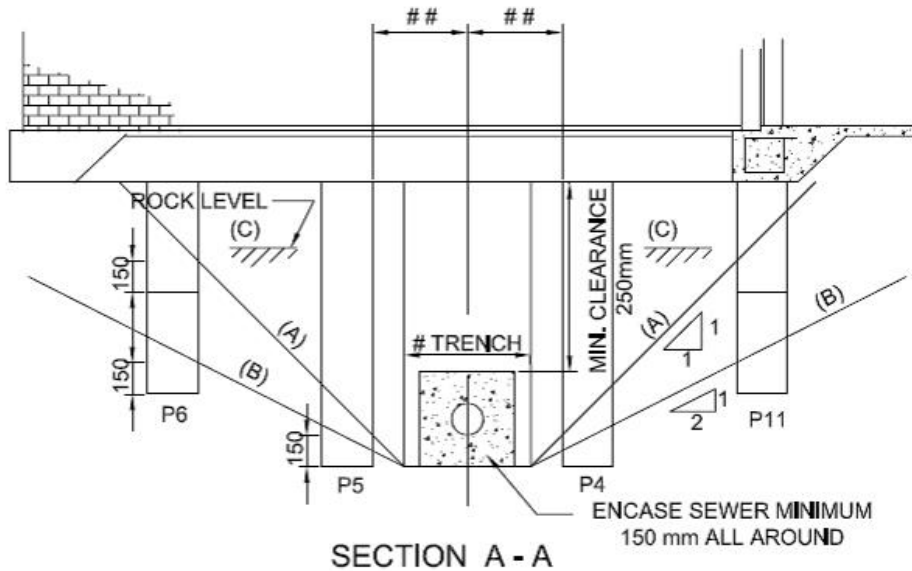
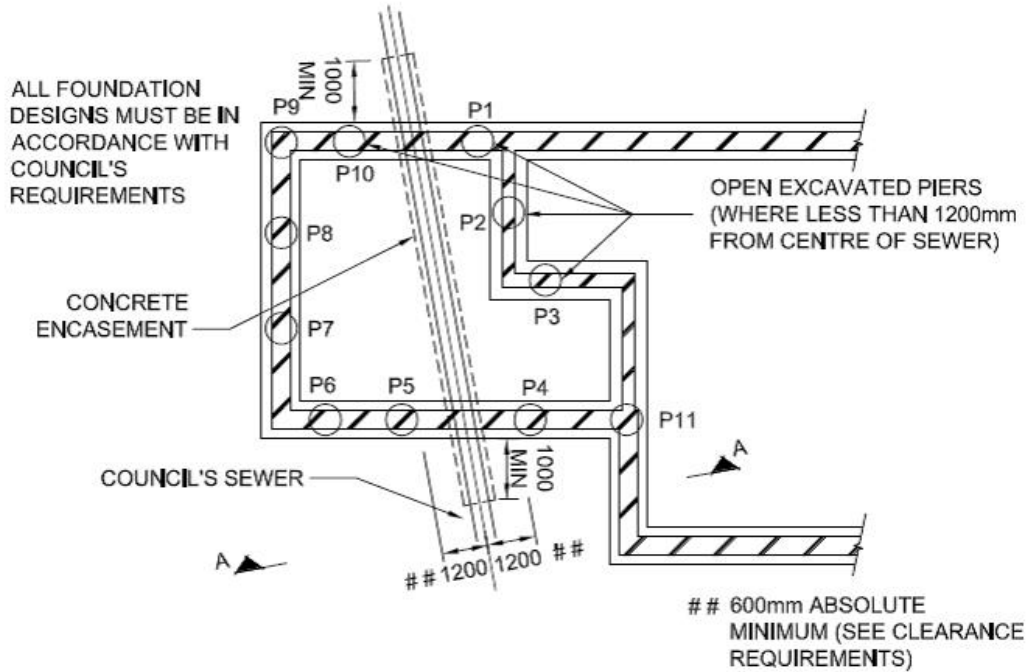

- (A) 1:1 ZONE OF INFLUENCE. SEWER IN CLAY, COMPACTED/CONSOLIDATED SOIL
- (B) 2:1 ZONE OF INFLUENCE. SEWER IN SAND, FILLED GROUND, LOAM, ETC.
- (C) IF ROCK OR HARD SHALE. PIER TO ROCK OR SHALE.

REFER APPENDIX A

Appendix C

PIERING OF FOUNDATIONS ADJACENT TO COUNCIL'S SEWER
TYPICAL DETAILS FOR 150Ø & 225Ø UPVC AND VC PIPES

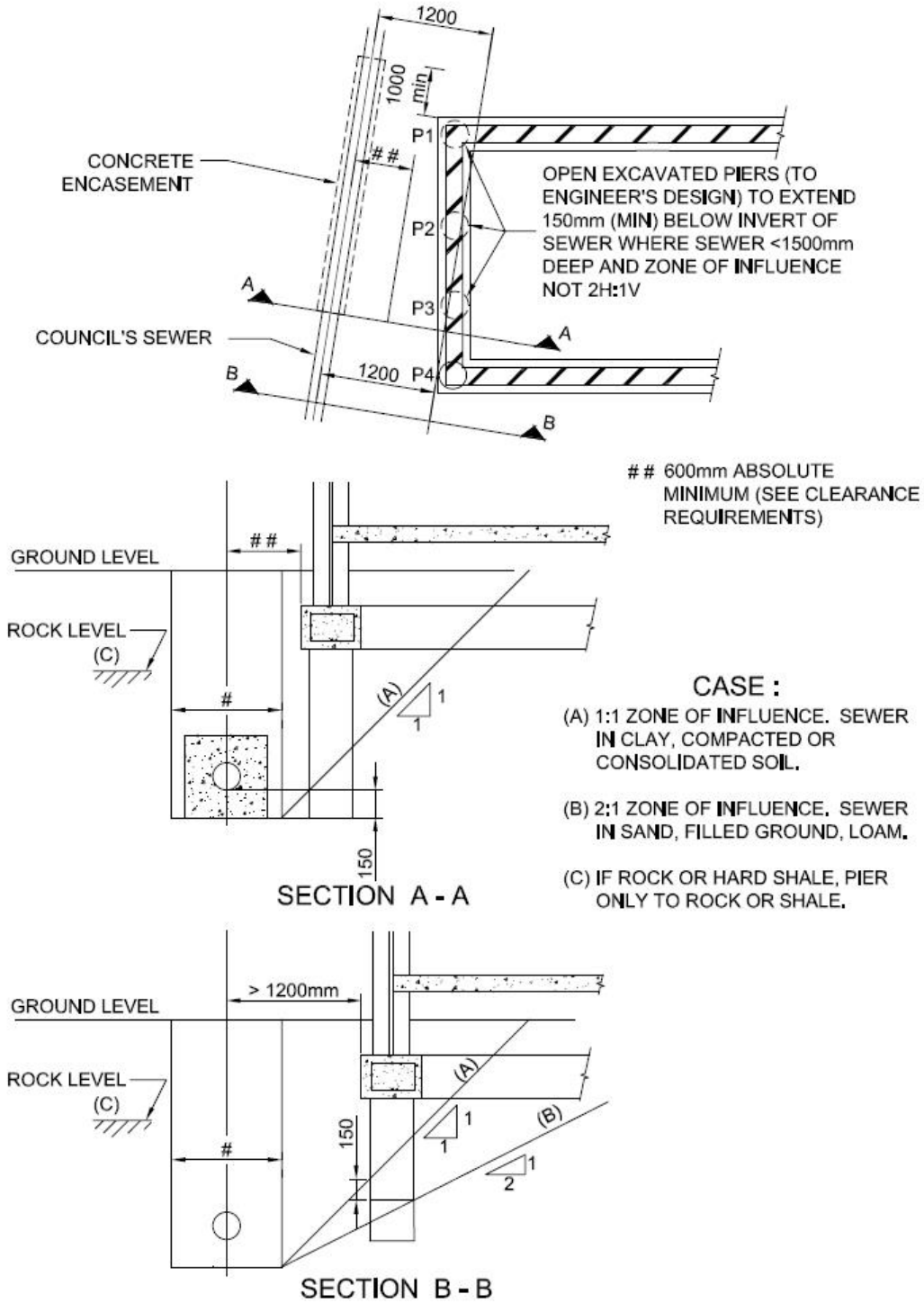

REFER APPENDIX A

Appendix D

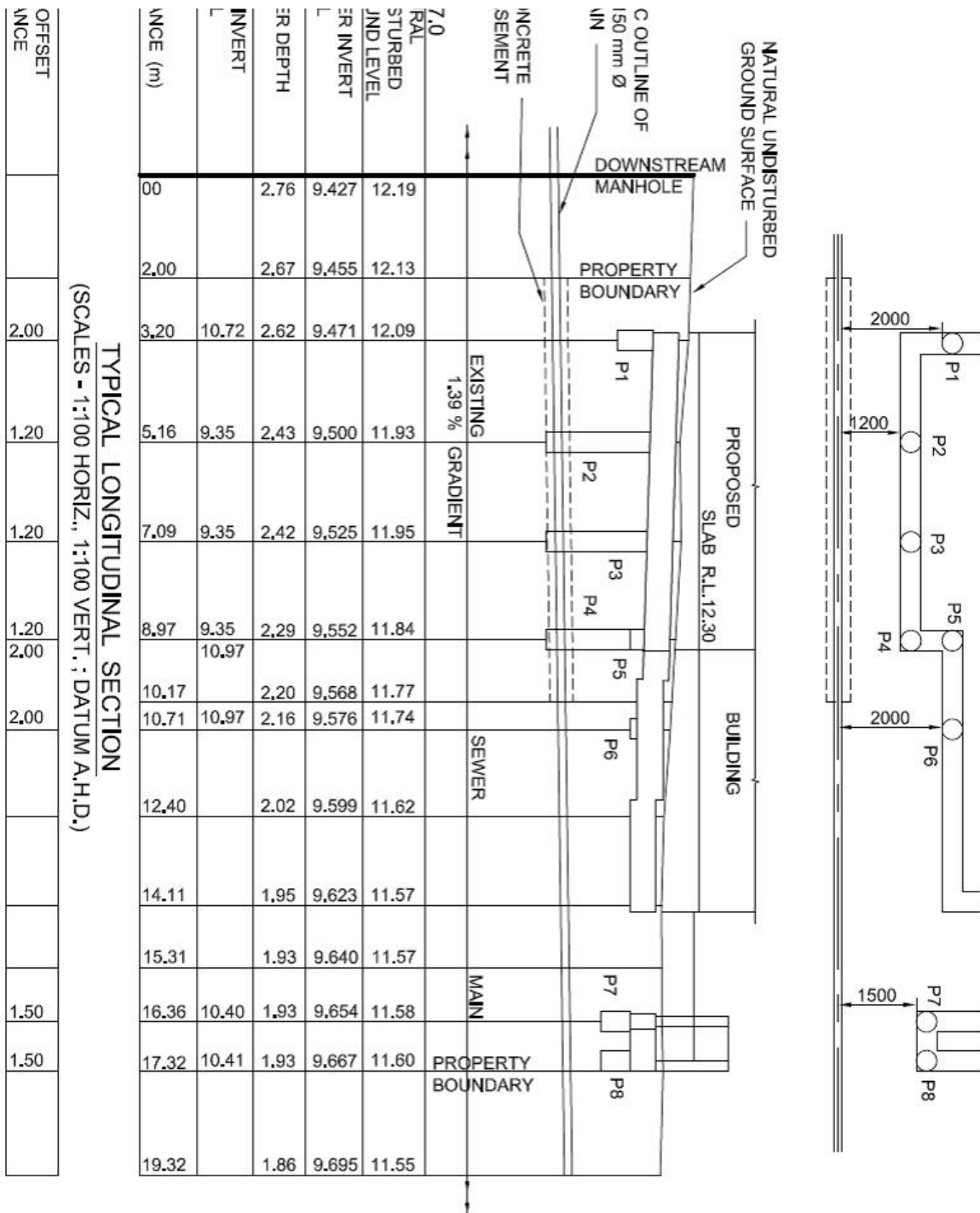

APPENDIX D